

SMART Bob 2

Model: SBRX II

Serial No.:

BINMASTER

Garner Industries • Lincoln, Nebraska • 68507 • USA • (402) 434-9102

Powerful. Reliable. Affordable.

- The strongest, smartest inventory measurement system on the market
- Measures solids, powders, liquids or slurries
- Minimal contact with stored material
- Service and maintenance-friendly in vessels up to 180 feet
- Sleek, robust, and lightweight housing
- Approved for hazardous locations
- No field calibration or adjustment
- Trouble-free mounting
- Wireless communication options available
- Easily scalable communication capabilities to meet your operational goals

SMART Bob 2

A powerful innovation in silo inventory measurement

Introducing  Direct-to-Web Inventory Tracking Software
The future of inventory tracking

SmartBob2 Introduction

The powerful and robust design of the SmartBob2 provides years of maintenance-free service in vessels up to 180 feet.



Measuring polystyrene in a polymer manufacturing facility.



Measuring dry feed supplements in bulk storage silos.



Measuring carbon black in a rubber belt plant.



Measuring sawdust at a wood product manufacturing facility.



Measuring salt submerged in water in a brine tank.

Robust SmartBob2 design

The SmartBob2 sensor combines technological advances and common sense to give you the strongest and smartest inventory measurement system on the market. The powerful and robust design of the SmartBob2 provides years of maintenance-free service in vessels up to 180 feet. It's built tough to succeed in demanding applications where other technologies fail.

Real smart

We've refined our technology and designed new innovations into the SmartBob2 to create a significantly advanced inventory measurement system. Through digital signal processing and advanced electronics, SmartBob2 gives you more communication options than any other system. We've made the best inventory measurement system even better, providing the most cost-effective and easiest-to-implement solution for maximizing your inventory control.

And versatile, too

SmartBob2 can handle the demands of virtually any application and vessel type. With numerous sensor probe styles, the SmartBob2 effectively measures solids, powders, liquids, or slurries. With a variety of mounting accessories, SmartBob2 can be used with almost any configuration of silo, bin, or other bulk storage vessels.

Proven applications

SmartBob2 has measured it all. Whether it's chunk coal in a coal fired power plant or fine granular solids in a plastic processor's material storage silo, SmartBob2 has the power and flexibility to handle it. Airborne dust, noise, steam, temperature, or varying material characteristics pose no problem to SmartBob2. It's capable of measuring all your liquids, large granular, powders and dry bulk solids applications. A high temperature

model is also available for applications where the process temperature is between 240° and 500°. This high temperature model is built with components designed to safely operate in temperatures up to 500°.

A trusted name

SmartBob2 has been developed by BinMaster, the proven, trusted name in inventory measurement systems. BinMaster employees put the needs of our customers at the center of all we do. We're proud of our 40-year history of service, quality, and integrity.

How SmartBob2 works

When a SmartBob2 positioned on the top of a vessel is asked to take a measurement, a heavy-duty motor releases a strong, stainless steel aircraft cable from the supply pulley and a weighted sensor probe quickly descends to the surface of the material.

During the decent, the SmartBob2 measures the cable dispensed by counting pulses with a high resolution microcontrolled optical sensing system. When the sensor probe touches the material surface, pulses are momentarily stopped and measurement information is transmitted. The absence of pulses also cause the motor to reverse and retract the sensor probe. A second confirming measurement is taken as the probe retracts and is compared to the descend measurement.

As the probe is retracted, motor torque is automatically reduced during the last 12" of the retract cycle resulting in a "soft retract seating," which extends the life of the SmartBob2 and ensures proper cable spooling.



Outstanding performance and durability built into every aspect of the SmartBob2

Numerous features in the design and construction of the SmartBob2 lead to its unsurpassed performance and exceptional durability.

Dual-compartment design

First among these is the innovative dual-compartment design of the SmartBob2. The mechanical compartment is completely separated from the fully-sealed electronic compartment. This protects the electronics from dust, debris, condensation and other contaminants, providing exceptional reliability and significantly extending the life expectancy of the unit. This signature feature is found on no other bob. The housing is also rated for hazardous locations.



Measuring heated molasses at a liquid feed plant.

Mechanical features

Stainless steel nylon-jacketed cable with 270-lb tensile strength, stronger than any brand on the market

Idle arm brake with adjustable spring tension stops sensor probe from sinking or sliding down the angle of repose in active vessels

Captive pulley system eliminates cables from jumping off pulleys

Sealed bearings, for trouble-free operation

Pulley channel scraper keeps pulley channels free of foreign materials

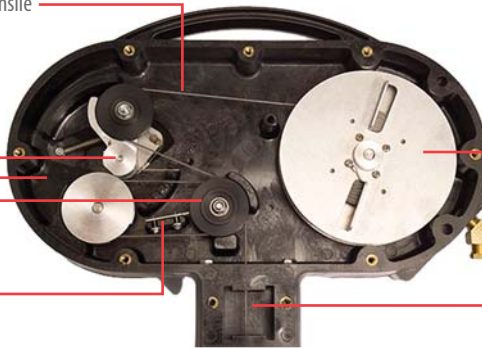

Cable-leveling supply pulley ensures proper cable wrapping and eliminates overlap

Standard air purge connection to ensure performance in extremely harsh environments

Four cleaning brushes wipe cable to keep debris out of mechanism (removable plate for easy access)

Electronic features

Heavy duty direct drive reversible motor with electronic torque control provides maximum pull strength

Optional motor gearbox heater keeps motor operating at peak performance in cold climates

Dual conduit entries

Powered by 110/220 VAC or 24 VDC

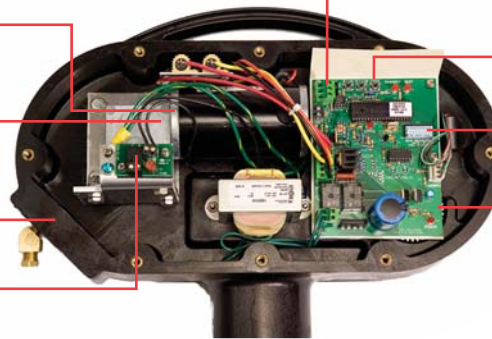

Removable wire terminals simplify installation

Test button to remotely initiate measurement

Dip switch panel to set each remote with a unique address

Protected optical encoder and sensor wheel

SureDrop

BinMaster's new SureDrop cable release system eliminates the sensor probe from sticking due to material buildup or freezing. The Teflon® cap and lower Teflon® ball seal the SmartBob2 mechanical cavity completely eliminating problems created by dust contaminating the unit when it's not taking a measurement. Should the Teflon®

cap stick when a measurement cycle is initiated, the sensor probe will begin to descend and the ball that's crimped to the cable directly above the cap will drop and strike the cap with the full weight of the sensor probe to dislodge it. The top Teflon® ball protects the cable and crimp.



eBob direct-to-web inventory tracking software was developed exclusively for use with SmartBob2 sensors.

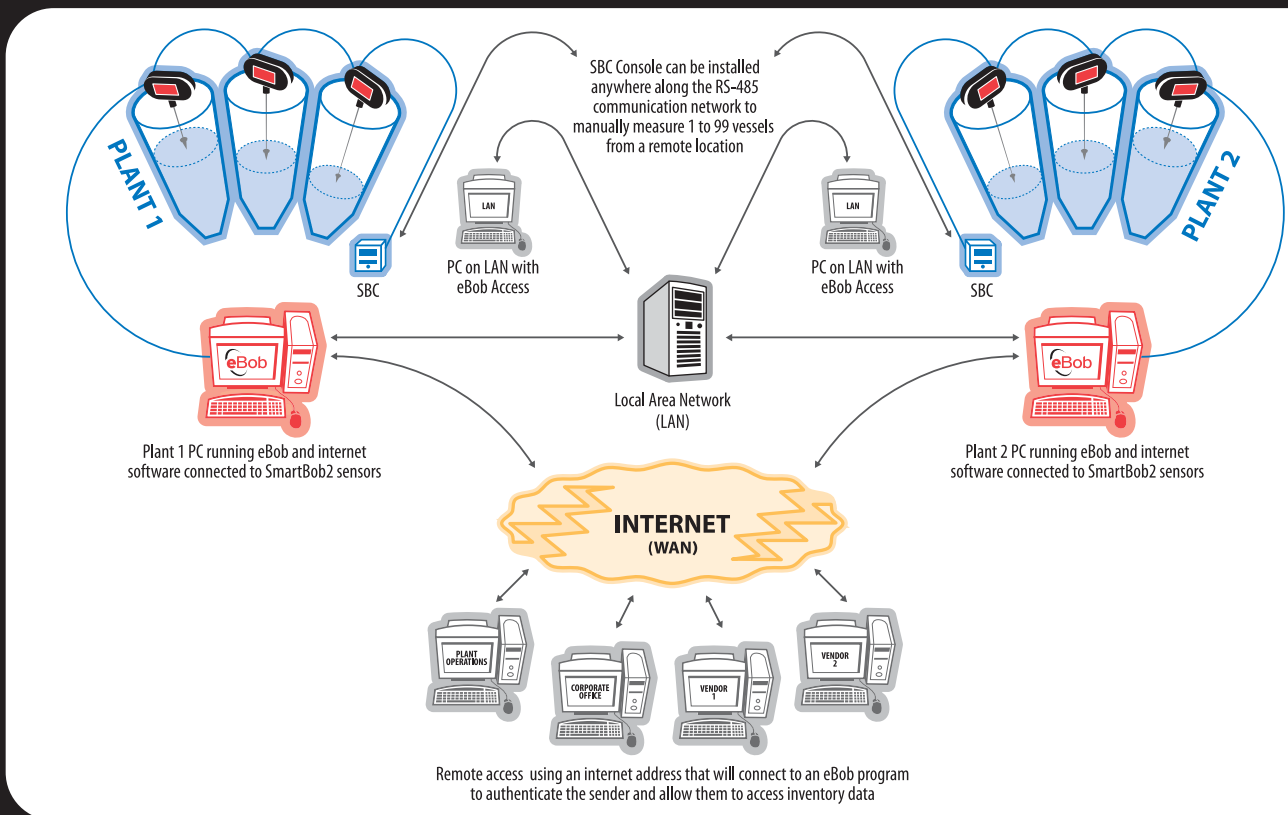

Manage critical inventory level efficiently with real time data on-demand

Improve your efficiency and optimize inventory levels with accessible real-time data. The powerful eBob information management system communicates preset or on-demand readings to any PC with internet access and proper authorization.

Remote and vendor managed inventory

Remote Managed Inventory (RMI) provides a more efficient method of product management between a supplier and customer. The use of a remote managed inventory system to monitor and control the usage of raw materials has brought important real time benefits to a wide range of industries, especially where bulk materials and liquids are a vital part of their process. This system allows vendors to keep a constant check on supplies of raw material at a particular customer site. By studying trends in usage, they can optimize their manufacturing schedules to meet expected demand and forward plan their delivery logistics. Vendor Managed Inventory (or VMI) is the process in which a vendor assumes responsibility for managing the inventory of a product at a customer's site. Timely inventory and usage data is essential to the Vendor Managed Inventory process.

The eBob software provides the real time inventory and usage data and the SmartBob2 sensor is a widely accepted method of reliably measuring bulk materials and liquids.

Completely customizable

Gather data from 1 to 100 SmartBob2-monitored vessels, at any number of locations. Configure your system to match your operational specifications so you can instantly share information with managers or vendors at multiple locations silo-by-silo, by vessel groups, or on a consolidated basis.

Simple, affordable, easy-to-use solution

The eBob system offers affordable solutions for any size application. Simple software is installed at a single site and can be up and running quickly. Open system design is easy to use and supports convenient data transfer.

eBob gathers critical data from SmartBob2 sensors

The SmartBob2 offers proven, reliable, accurate inventory measurements of solid, liquid, and slurry material. The robust design of the remote sensor will provide years of maintenance-free service in vessels up to 180 feet.

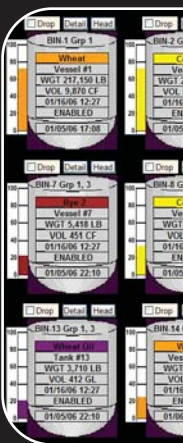

eBob software system is a powerful innovation in silo inventory management.

Discover the Power of eBob

PRODUCT	BIN	MEASURE DATE	VOL	WG	HT	SR VOL	SR WG	SR HT	% FULL
Wheat	1	01/23/06 09:18	2,891	43,379	10.4	11,152	245,537	24.7	20.5%
Corn A	2	01/23/06 09:18	1,672	50,512	7.1	7,210	252,549	23.0	18.8%
Rye 1	3	01/23/06 09:18	4,199	50,382	33.3	242	3,100	1.8	94.1%
Grain A	4	01/23/06 09:18	6,044	132,966	23.8	318	6,998	1.3	95.0%
Wheat	5	01/23/06 09:18	4,774	108,564	23.8	251	5,530	1.3	95.0%
Grain B	6	01/23/06 09:18	1,865	41,027	23.8	90	2,159	1.3	95.0%
Rye 2	7	01/23/06 09:18	1,865	22,378	23.8	90	1,178	1.3	95.0%
Corn A	8	01/23/06 09:18	1,865	48,270	23.8	90	3,435	1.3	95.0%
Corn Oll 1	9	01/23/06 09:18	1,865	33,547	23.8	90	1,747	1.3	95.0%
Corn Oll 2	10	01/23/06 09:18	1,865	16,784	23.8	90	883	1.3	95.0%
Soy Beans 1	11	01/23/06 09:18	1,865	44,421	23.8	90	2,454	1.3	95.0%
Wheat	12	01/23/06 09:18	184	4,319	2.5	1,747	38,847	22.5	10.5%
Wheat Oll	13	01/23/06 09:18	1,865	16,784	23.8	90	883	1.3	95.0%
Wheat	14	01/23/06 09:18	1,865	41,027	23.8	90	2,159	1.3	95.0%

BinMaster is your single source

The eBob software has been developed by BinMaster, the proven, trusted name in inventory measurement systems. BinMaster is your single source for customization, support, and upgrades—there are no third party applications, no monthly access fees, and no special training or support required.

Discover the power of eBob

The eBob software is a powerful innovation in silo inventory management. The eBob allows direct-to-web inventory tracking from any PC with internet access. The eBob software gathers data from our SmartBob2 sensors to monitor inventory levels in up to 100 vessels.

Vessel shape correction

When the SmartBob2 sensor measurement exceeds the straight wall vessel height, a cone volume correction can be set up. The correction factor models the cone section of a vessel by applying a height and radius to multiple “bands” or sections of the cone and subtracting this from the overall volume.

Automatic alerts

Alarm settings provide automatic notification alerts via e-mail if critical inventory levels are reached.

Data history and trending

Microsoft® Access compatible files store current and historical measurement data. All data can be easily transferred to other software programs for data analysis or archiving. A basic reporting screen provides comprehensive data from the last measurement of each vessel. A string report is also available to show a history trend of the past 30 measurements for each vessel.

Access vessel data instantly with the SBC Console

The SBC Console is the most popular way to remotely initiate and view vessel measurements.

Whether you use SmartBob2 sensors with or without the eBob software, the SBC Console gives you instant measurement readings with the push of a button. This compact, manually-operated console can control from 1 to 99 SmartBob2 sensors.



When you are using the eBob software, there are still times you may want to initiate readings independently from a remote location—such as a truck load out station. You can make numerous measurements without affecting the eBob software’s long-term data memory or trending information.

Individual bin heights are programmed into the SBC Console and measurements are displayed as distance to product, height of product, and percent full. The display also indicates the status of the bob during the measurement cycle. Most recent bin heights and percent full data is retained in the SBC memory, even in instances of power loss.

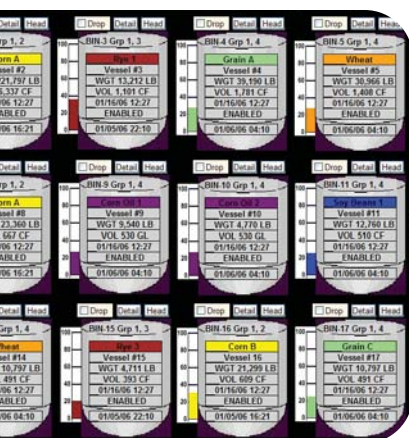

The powerful software provides an unsurpassed graphical representation of critical inventory data, including:

- vessel number and group (view data for up to 20 vessels at one time)
- vessel contents and title
- distance to product (headroom)
- height of product
- vessel percent full
- product weight
- product volume
- date/time of last and next measurement
- status of measurement device (descending, retracted, inactive, plus error messages).

A second detail screen provides an expanded data readout for any individual vessel.

Automatic measurements

The eBob system can be programmed to take automatic measurements at preset intervals and allows you to send vital information via e-mail.

Communication Accessories

Remotely initiate and view vessel measurements.

SBC push button console

The SBC Console is the simplest way to remotely initiate and view vessel measurements. This compact, manually-operated console can control from 1 to 99 SmartBob2 sensors with the push of a button. Individual bin heights are programmed into the console and measurements are displayed as distance to product, height of product, and percent full. The display also indicates the status of the Bob during the measurement cycle. Bin heights and percent full data of the most recent measurements are retained in the SBC memory, even in instances of power loss. See additional details on the previous page.

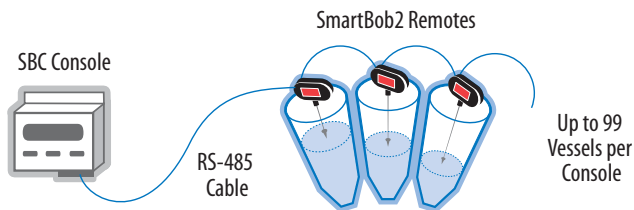

Remote Start Unit (RSU)

The RSU provides a variety of enhancements to the SmartBob2 system: an external start input, a 4-20mA current loop (analog) output, and a remote display or remote readout of the measurements. These enhancements allow for a simple interface between the SmartBob2 Sensor and Programmable Logic Controllers (PLC) or Distributed Control Systems (DCS). The PLC \ DCS can initiate a measurement by providing a dry contact closure to the RSU. The PLC can then retrieve the measurement from the analog 4-20mA current loop output on the RSU. The remote readout feature allows you to view the current measurement information at each vessel or in a control room away from the controlling PLC or DCS. The display provides distance to product, height of product, percentage of product in the storage vessel, and status of the bob. The most recent measurement and user information is stored in nonvolatile memory (data is retained even in event of power loss).

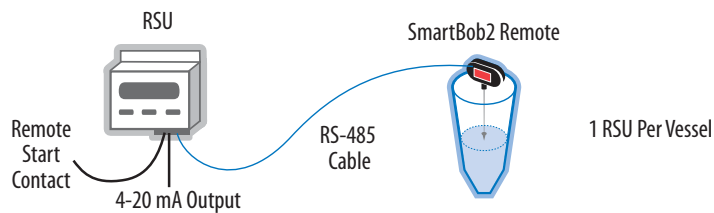

SmartBob2 MUCM communication module

The MUCM is a communication module capable of translating the SmartBob2 serial protocol to Modbus RTU, Ethernet, DeviceNet™, Modbus Plus™, or Profibus protocols. The example below shows a Modbus serial master gathering data from three SmartBob2 Sensors. The data from each SmartBob2 sensor is presented as a Modbus Holding Register (4x). Each bob is assigned a unique Modbus slave address. A special Modbus slave address of 247 is provided to initiate a measurement and to give a summary of all the measurements from the SmartBob2 Remotes in the network.

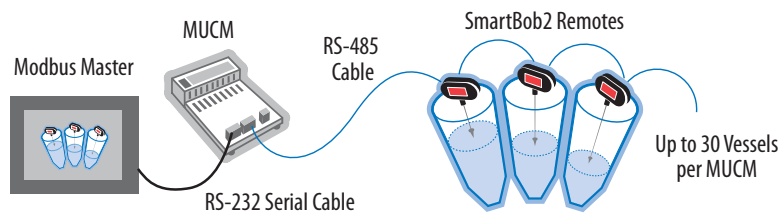

SmartBob2 QUCM-OE communication module

This system is designed to allow an industrial control system such as an HMI, SCADA, PLC, or DCS system to monitor and control up to sixty-four SmartBob2 Remotes via ethernet. Additionally, the system will allow a web browser to monitor and control the connected SmartBob2 Remotes. Alternately, the system allows for a serial Modbus RTU or Modbus ASCII master to monitor and control up to thirty-two SmartBob2 Remotes, while still allowing Modbus/TCP and web access via ethernet.

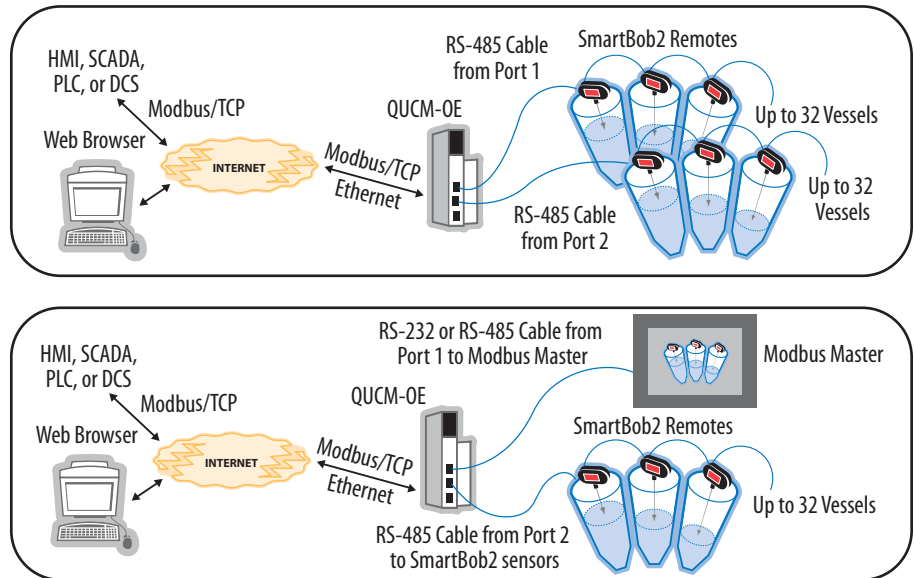

Wireless data transmitters

BinMaster's wireless data transceiver eliminates the need for running long spans of communication cable by providing affordable, two-way wireless data communication between SmartBob2 sensors mounted high on top of storage vessels and a control source on the ground. BinMaster's long-range wireless data transceiver operates in the license-free portion of the FCC designated industrial frequency band at 900 MHz. Designed to work in high interference environments, the wireless transceivers combine advanced frequency hopping and digital signal processing technology with outstanding receiver sensitivity and antenna diversity, resulting in exceptional noise and interference rejection and peace of mind for you. Wireless data networks can be effective in new SmartBob2 installations, as an alternative to wired connections. They can also be used to expand the capabilities of existing systems.

A Point-to-Point single network wireless solution eliminates running RS-485 communication cable from the control source on the ground to the first SmartBob2 sensor in a single grouping of vessels.

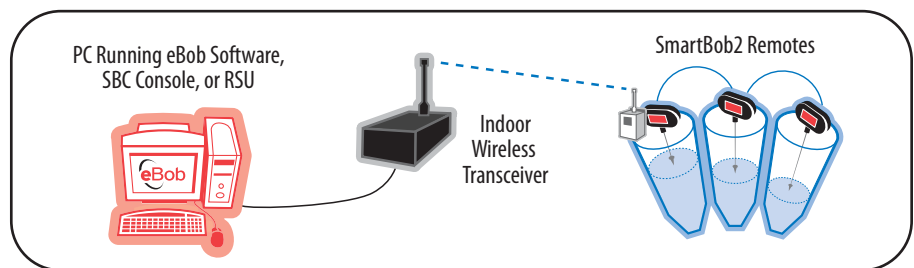

A Multi-Point single network wireless solution eliminates running RS-485 communication cable from the control source on the ground to the first SmartBob2 sensor in multiple groups of vessels.

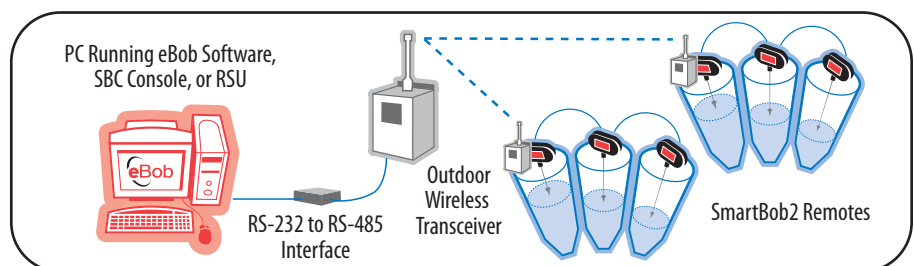

316 stainless steel spike sensor probe



The spike is designed for solid materials with a bulk density greater than 20 lb./cu. ft. The spike can also be used to torpedo through a liquid to find and measure a submersed solid in an interface application. This spike works well in corrosive materials and foodstuffs. A Teflon® coated spike is available for sticky materials.

416 stainless steel spike sensor probe



The spike is designed for solid materials with a bulk density greater than 20 lb./cu. ft. This spike is made of 416 stainless steel to allow it to be picked up by a magnet.

Digestible bottle



Polyethylene bottle can be purchased empty and filled with material compatible with the material stored in the vessel or filled at the factory with a food grade paraffin wax. It's called a "digestible" bottle because it can pass easily through a rotary valve or screw conveyor.

4" inverted stainless steel cone



The 4" inverted stainless steel cone is hollow and designed for use with light, solids and powders with a bulk density greater than 8 lb./cu. ft. Stainless steel construction offers long life even in corrosive materials and foodstuffs. A Teflon® coated cone is available for sticky materials.

6" inverted stainless steel cone



This hollow inverted stainless steel cone is designed for use in liquids or light, bulk solids and powders with a bulk density greater than 3 lb./cu. ft. This sensor probe works well in corrosive materials and foodstuffs. A Teflon® coated cone is available for sticky materials.

Mounting flanges



SmartBob2 sensors can be ordered with flat- or angled-mount flanges for mounting on sloped roof vessels. The flanges are available in 0°, 5°, 10°, 15°, 20° and 30°.

Gearbox heater



SmartBob2 can be ordered with a motor gearbox heater and thermostat when the SmartBob2 Remote will be exposed to temperatures consistently below 32° F. The heater will assure the motor operates at 100% efficiency.

Pipe extension



The pipe extension is an optional feature that is attached to the SmartBob2 mount. The pipe extension keeps the sensor probe from being pulled up into a stand-pipe, functions as a bushing, and keeps the cable from fraying on sharp objects. It also functions to keep the sensor probe flush with the vessel top. The extension pipes are available in CPVC, galvanized, or stainless steel. They are available in custom lengths from 4 inches to 20 feet.

BINMASTER

Division of Garner Industries
PO Box 29709 / Lincoln, NE 68529
7201 North 98th Street / Lincoln, NE 68507
(402) 434-9102 Fax (402) 434-9133
www.binmaster.com

SMART Bob 2

**For more information
call 1-800-278-4241**

ISO 9001 Certified